

**ID-Nr. 41429-047**  
**Model IO90.195.120.PS.WDC**



**Safety storage cabinet for lithium-ion batteries ION-PRO-90 Model IO90.195.120.PS.WDC, body colour anthracite grey (RAL 7016), with wing doors in gentian blue (RAL 5010)**

**Function / construction:**

- **Robust construction and longevity:** robust, high-quality, scratch-resistant outer body with powder-coated textured surface
- **Easy handling with comfort:** smooth doors with permanent self-closing function and oil-dampened door closer; open doors with a minimum amount of force
- Integrated potential-free alarm contact for strongly recommended alarm forwarding. Optionally available with relay module and module for remote signalling.
- **No unauthorised use:** doors lockable with cylinder locking (integration in an existing locking system possible) and locking state indicator (red/green). Permanent locking of the doors by automatic 2-point locking.
- **Integrated transport base:** In the event of an emergency, immediate evacuation and transport of the cabinet to a safe place outdoors.
- **Easy alignment:** adjusting aids to compensate for uneven floor
- Smoke detector and temperature sensor for fire detection and forwarding the alarm to the building management system.
- Pressure relief in the head section
- **All-around protection:** 90 minute fire protection from outside to inside (type 90 / type tested in accordance with EN 14470-1) and for more than 90 minutes fire resistance for fires from inside to outside
- LED display with visual and audible alarm for a quick indication of emergencies without opening the cabinet doors.

Dimensions	
Width (external)	1193 mm
Depth (external)	615 mm
Height (external)	1953 mm
Width (internal)	1050 mm
Depth (internal)	503 mm
Height (internal)	1647 mm

Weight / Load	
Net weight configuration	484.00 kg
Distributed load	563 kg/m <sup>2</sup>
Maximum load	600 kg

Colouring / Surface finish	
Body colour code	RAL 7016
Body colour	anthracite grey
Body surface finish	textured
Door / Drawer colour code	RAL 5010
Door / Drawer colour	gentian blue
Door / Drawer surface finish	textured

General Information	
Number of doors	2
Door opening angle	89.50°
Depth with open doors	1166.00 mm
Entry width transport base	1120 mm
Entry height transport base	90 mm
Customs tariff number	94032080

Front view

Side view

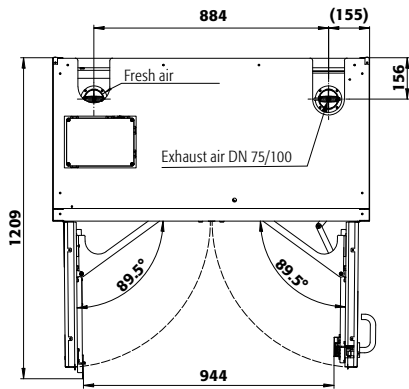
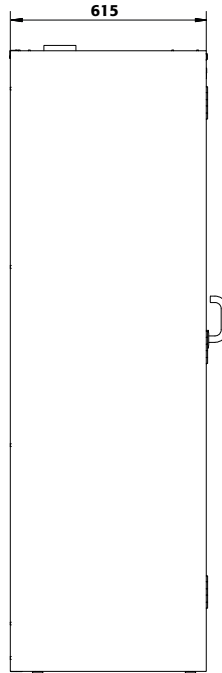
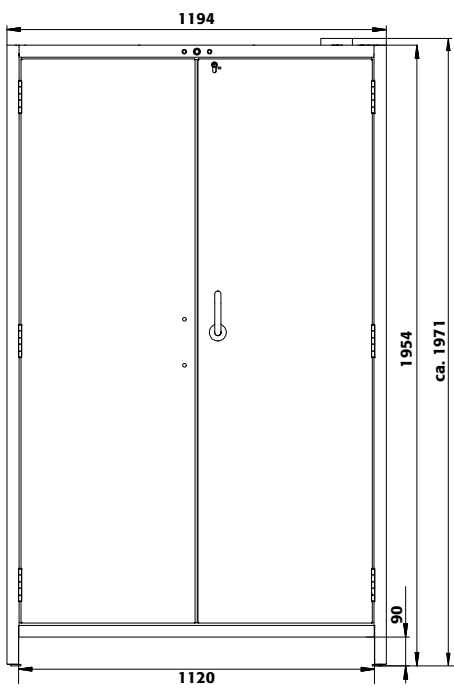

For further information please visit [www.asecos.com](http://www.asecos.com)