

EN

EP.V.37174.00 | 03/2026

asecos®

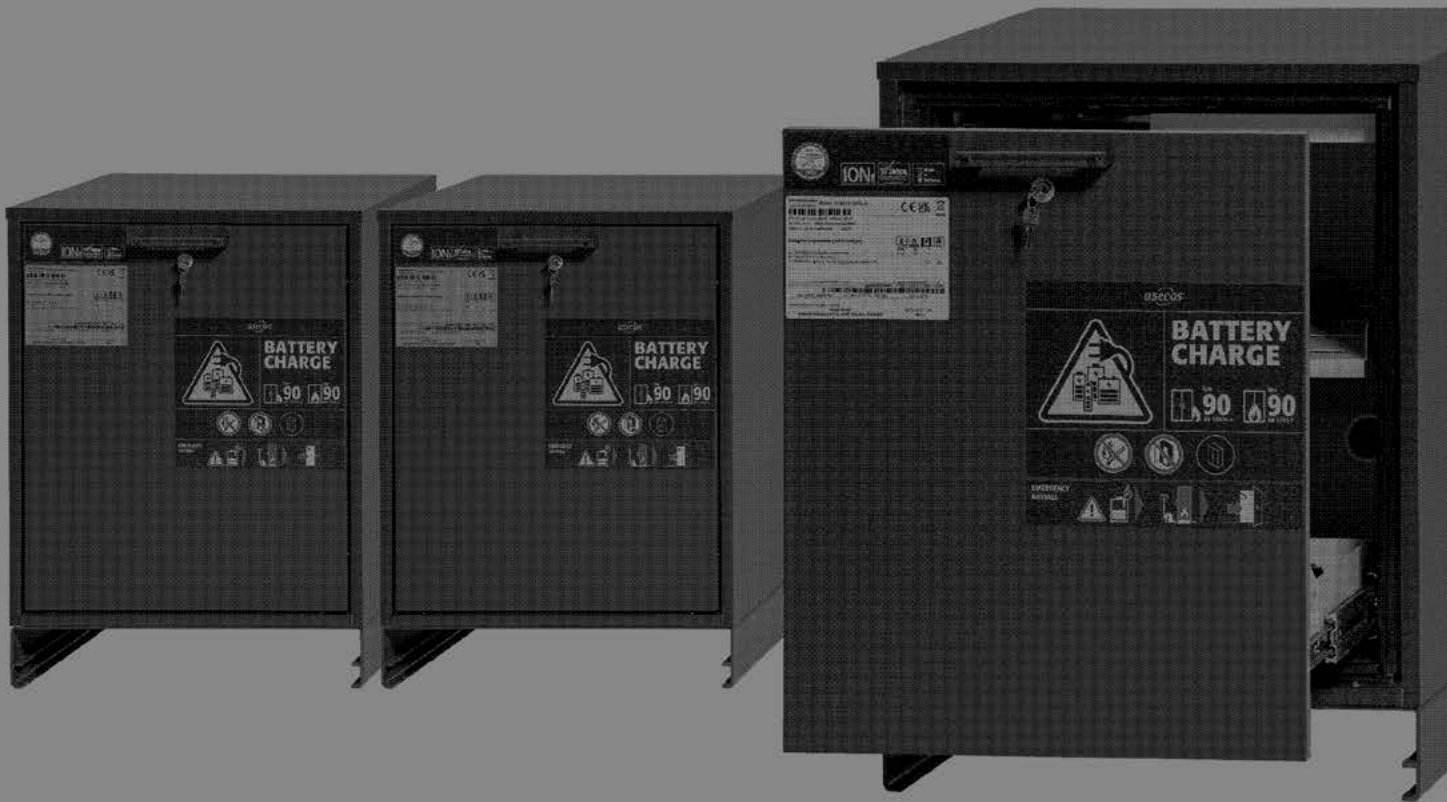

ION
LINE

USER MANUAL

Safety storage cabinets for storage
and charging of lithium ion batteries

ION_{LINE}

ION-CHARGE-90



IO90.078.059.057.U9.S



IO90.078.059.057.U1.S



asecos GmbH
Customer service
Weierfeldsiedlung 16-18
D-63584 Gründau

Fax: +49 60 51 - 92 20-10
email: service asecos.com

YOUR PERSONAL DOCUMENTATION TO THE asecos SAFETY CABINET

Dear Customer,

you have made a decisive investment in safety for your company by purchasing this asecos safety storage cabinet. You now own an innovative product made of top-quality materials guaranteeing the highest quality standards.

asecos safety storage cabinets have complete authorisation documents. We archive the authorisation documents for every individual cabinet, keeping them ready for you should you ever need them (e.g. for a works inspection or similar). Simply request them using this form.

Tear of or copy that page and return to us by fax with your address and serial number of the cabinet on it.

Yours sincerely
asecos GmbH

Contact

Company		
<input type="text"/>		
Street	Postal code	Town
<input type="text"/>	<input type="text"/>	<input type="text"/>
Name of contact person		
<input type="text"/>		
email	Phone No.	
<input type="text"/>	<input type="text"/>	
Serial numbers of safety storage cabinets		
<input type="text"/>	<input type="text"/>	<input type="text"/>
<input type="text"/>	<input type="text"/>	<input type="text"/>
<input type="text"/>	<input type="text"/>	<input type="text"/>

OPERATING INSTRUCTIONS

Dear customer,

Thank you very much for purchasing a safety storage cabinet from our company, with which you have made a decisive investment in the safety within your company. Our safety storage cabinets make the storage of hazardous materials at the workplace safe and convenient for you.

Please read these operating instructions very carefully. Get to know the advantages and simple operability of our safety storage cabinets in detail. This simplifies the daily handling of hazardous materials for you.

Many thanks
Your asecos team

1. NOTES ▪ GUIDELINES ▪ GUARANTEE	5
1.1. General safety notes	5
1.2. Safety instructions for the storage of lithium-ion batteries	5
1.3. Guarantee.	5
1.4. Cabinet Details.	5
1.5. Marking and symbols on the cabinet	6
2. TRANSPORT	6
2.1. Tilting the cabinet	6
2.2. In-plant transport	6
3. INSTALLATION	7
3.1. Alignment Of The Cabinets	7
4. COMMISSIONING	7
4.1. Connection to the power supply	7
4.2. Self-Test	8
4.3. Potential-free alarm contact	8
5. CLOSING	9
5.1. In general	9
5.2. The drawer gets stuck while closing	9
6. INTERIOR FITTINGS	9
6.1. Bottom collecting sump.	9
6.2. Second pull-out level.	9
6.3. Storage levels with power socket strips	10
6.4. Total power rating of the power socket strips	10
7. STORAGE	10
7.1. General information on batteries	10
7.2. Notes on storage and charging	11
8. VENTILATION	11
9. SMOKE DETECTOR	11
10. ERROR ▪ FALSE ALARMS	11
10.1. Error during self-test	11
10.2. False alarm of the smoke detector	11
11. ALARM OVERVIEW	12
11.1. Error and alarm overview.	12
11.2. smoke alarm.	12
12. BATTERY FIRE ▪ EVENT OF FIRE ▪ DISPOSAL	12
12.1. Opening the cabinet after the fire.	12
12.2. Disposal	12
13. SAFETY CHECKS	13
13.1. Cleaning	13
13.2. Contact	13
14. TECHNICAL DATA	13
15. TECHNICAL DRAWING	13

1.1. GENERAL SAFETY NOTES

- When handling lithium-ion batteries, observe the applicable regulations and the information in these operating instructions
- Work on the electrical system is to be carried out only with the power turned off and only by qualified electricians – refer here to the regulations of the local electricity supply company.
- General damage to electronic components is to be repaired without delay by an asecos employee.
- Use only intact and undamaged mains cables for the battery charger
- Electrical protection in accordance with local standards must be provided by the customer (cabinets do not have their own RCD circuit breaker or circuit breaker)
- The on-site installation conditions are to be observed.
- The instructions of the supervisory engineering department must be followed.
- Observe accident prevention regulations and workplace ordinance
- **Ensure that the necessary safety checks are only carried out by authorised staff using original spare parts**
- Only use the cabinet after having been properly instructed; access is to be forbidden to unauthorised persons.
- By assigning trained/authorised technical personnel you can prevent the malfunctions, damage and corrosion damage that result from inappropriate transport.
- ION-LINE safety storage cabinets are designed exclusively to store and charge lithium-ion batteries. Storing them together with other (hazardous) substances is not permitted.
- The area in front of the drawer must always be kept clear; the drawer must be kept closed
- Before the initial commissioning, the safety storage cabinet is to be examined by the user for possible damage.
- **Observe the notes on maximum size and general storage of the batteries in these instructions**

Set-up requirements

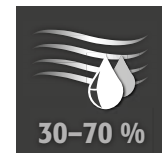
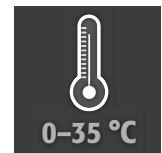

1.2. SAFETY INSTRUCTIONS FOR THE STORAGE OF LITHIUM-ION BATTERIES

- Follow the instructions for storing your batteries in accordance with the battery manufacturer's operating instructions
- A risk assessment must be conducted. The results will determine whether additional safety measures are necessary to minimize the risk of toxic or flammable gases in the work area.

1.3. GUARANTEE

The guarantee for this product is agreed between you (the customer) and your dealer (the seller). As the manufacturer, asecos guarantees the products listed in the operating instructions for a period of 24 months from the date of delivery. All model safety equipment are subject to a compulsory annual inspection by specialised staff authorised by the manufacturer. Otherwise the customer's guarantee claim against the manufacturer expires. Please note that the warranty is also void if holes are drilled or modifications are made without consulting the manufacturer asecos.

1.4. CABINET DETAILS

Cabinet data: logbook (included with the cabinet)
Technical drawing: see appendix
Technical data: table in appendix









ION-CORE-90 UB

Safety storage cabinets for lithium-ion batteries Comprehensive fire protection with the proven evacuation and alarm relay concept.

During active storing, lithium-ion batteries or battery packs are charged or partially discharged (60–70%) in the cabinet using a charger.

Model	Lithium ion batteries				
	Storing	Charging	Extraction air system	Fire suppression unit	Alarm system
ION-CORE-90					
IO90.078.059.057.U9.S	✓	✓	✓		✓
IO90.078.059.057.U1.S	✓				✓

1.5. MARKING AND SYMBOLS ON THE CABINET

 90 minutes of fire resistance level, both inside and outside	 Highest safety level – NOT available on CORE models	 With three-point locking – NOT available on CORE models
 Using smoke detectors for flue gas monitoring	 Very high smoke-tightness – NOT available on CORE models	 With additional VDMA 24994 certification – NOT available on CORE models
 With an alarm system	 Doors close automatically – NOT on CORE models	 With advanced alarm forwarding – NOT available on CORE models

2. TRANSPORT

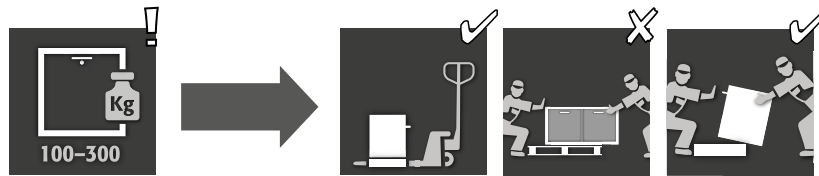

CAUTION:

Transport the cabinet in an upright position on a pallet truck, tied and secured against slipping, until the final place of installation is reached. The transport locks in the door joints may only be removed directly at the place of installation! Inappropriate transport can lead to concealed damage to the fire protection insulation! We can only guarantee the necessary quality if the cabinet is transported to the place of its use by our specially trained staff.



ATTENTION:

The clear entry width of the base is 545 mm. It is essential that you take this into account when selecting your pallet jack! Equipment with load widths greater than the entry widths must not be used.

2.1. TILTING THE CABINET

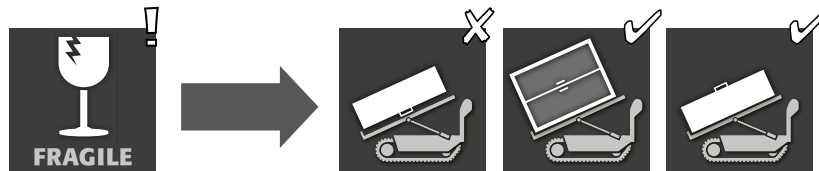

CAUTION:

Tilting the cabinet may only be done without jolts! When using a stair robot, observe the maximum load capacity of the device according to the manufacturer's instructions!

2.2. IN-PLANT TRANSPORT

- In-plant transport is also possible without transport locks (inserted as standard in the door joints)



CAUTION:

The drawer must be locked before transport!

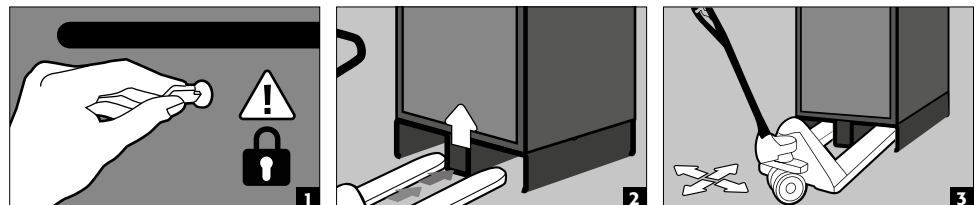

Includes a base with casters

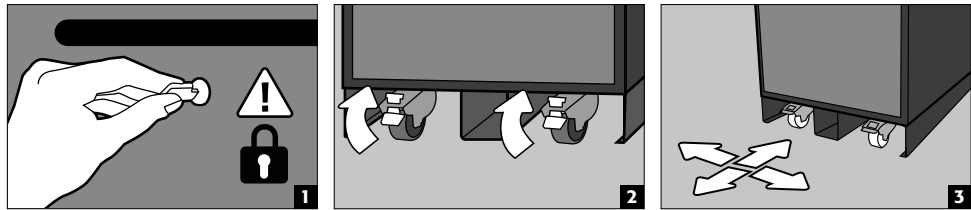

3. INSTALLATION

3.1. ALIGNMENT OF THE CABINETS

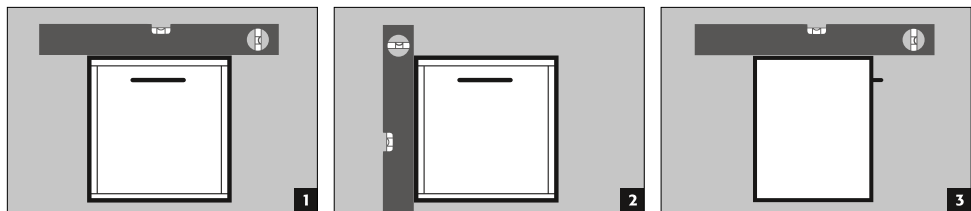
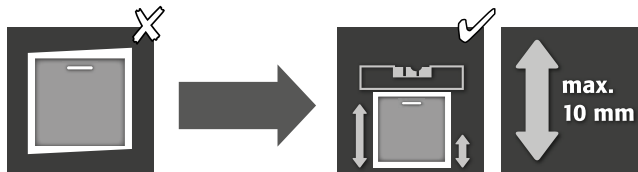

CAUTION:
 Door and drawer components must not rub against the fire-resistant gaskets in the door/drawer rebate when opening and closing!

4. COMMISSIONING

- Before putting into operation for the first time, the user must carry out an examination of the safety storage cabinet for possible damage, such as defective or loose sealing elements, correct alignment and perfect functioning of the door elements. Use the cabinet and accessories only if they are in an orderly condition.

4.1. CONNECTION TO THE POWER SUPPLY

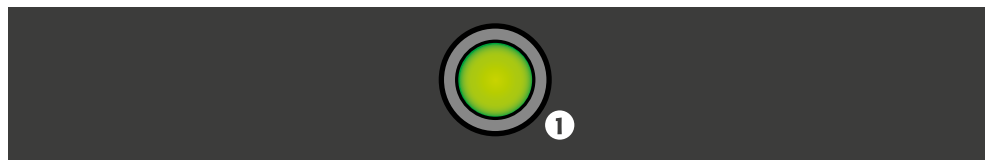
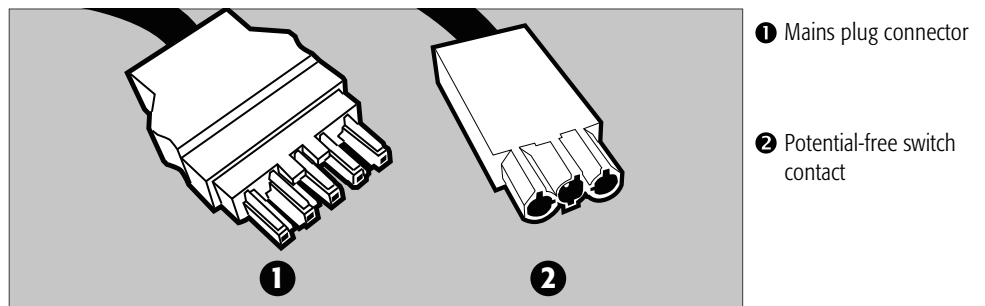

1 LED: Operating (green) / Error (red)

Connection to the power supply

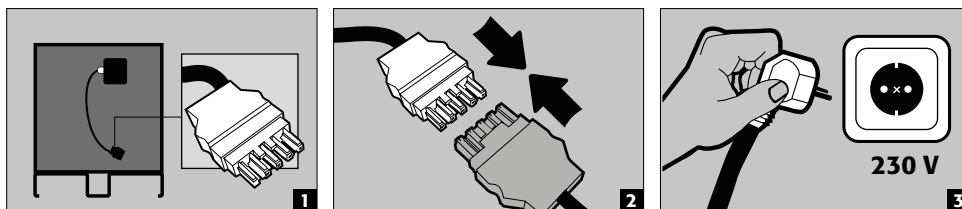

NOTE:

Retrofitting is easy due to the plug-in connection, so that no intervention in the electrical components is necessary. The power supply must be fused on site with a maximum of 16A. Electrical protection in accordance with local standards must be provided on site. The cabinets do not have their own RCD circuit breaker or circuit breaker.

4.2. SELF-TEST

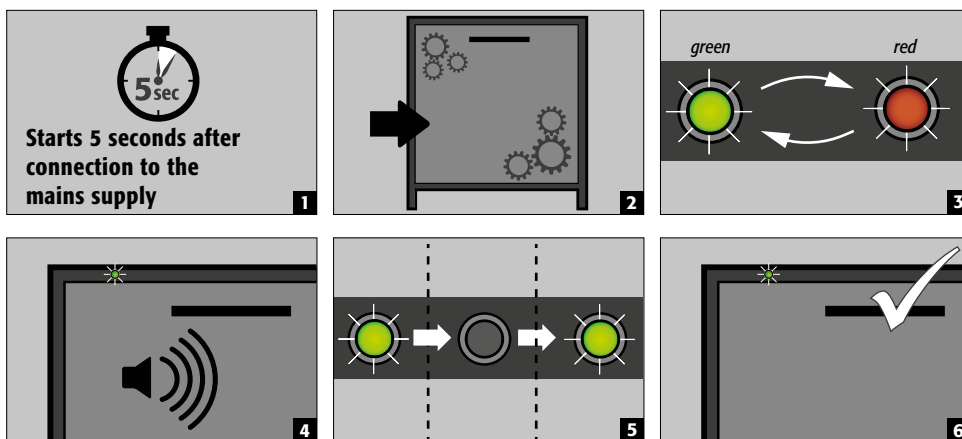

ATTENTION

If the self-test does not end with a steady green LED, see the section "Self-test error"

4.3. POTENTIAL-FREE ALARM CONTACT



NOTE:

The potential-free alarm contact is used to connect a signal to a control centre/control room. Direct integration into a fire alarm control panel (FACP) is not recommended or may only be carried out in consultation with the person responsible for the system.

However, it is always recommended to connect the signal to a manned control centre/control room!

The potential-free switching contact must always be connected by the customer (not a service).

Contact configuration – Normal operation: "L" and "1" are connected; Alarm or power failure: "L" and "2" are connected

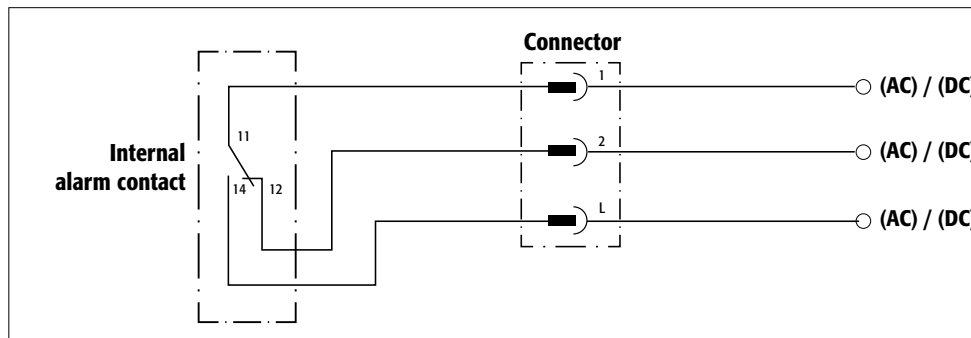

Connection instructions

- Use only the supplied mating part (colour-coded brown) to the plug for the connection.
- The connection must be done by a qualified electrician.
- The internal switch contact is designed for a max. DC voltage of 24 V or a max. AC voltage of 230 V.

- The maximum current load is 5 A at 230 V AC and 10 A at 24 V DC.
- The internal switch contact is a changeover contact; in case of alarm, therefore, the switching state may be queried as „opened“ or „closed“.

5. CLOSING

5.1. IN GENERAL

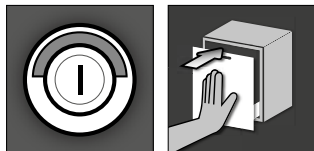

- The lockers have a profile cylinder lock with locking status indicator.
- They can be integrated into a locking system.
- A profile half cylinder (30/10) with adjustable locking lug must be used.



ATTENTION:

The drawer is not permanently self-closing. If the contents of the cabinet are not being accessed, the owner/user must ensure that the drawer is kept closed. The drawer is equipped with a thermal release mechanism and closes automatically in the event of a fire.

5.2. THE DRAWER GETS STUCK WHILE CLOSING



ATTENTION:

If the drawer is blocked during the closing process and cannot close completely, the cabinet will signal a malfunction after 60 seconds. The LED will flash green and an intermittent tone will sound. Remove the obstruction and close the drawer. The error message will clear.

6. INTERIOR FITTINGS

6.1. BOTTOM COLLECTING SUMP

Leaks:

- Liquid in the sump is to be collected using suitable means.
- The choice of means is your own responsibility.

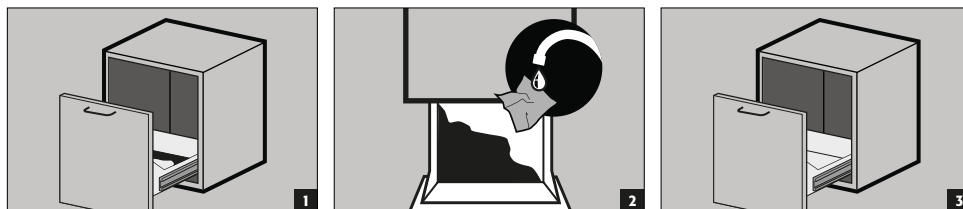

6.2. SECOND PULL-OUT LEVEL

- **Normal operation:** Pull the second pull-out level out of the cabinet by hand and push it back in
- **Fire:** Thermal trigger; the second pull-out level that has been pulled out is automatically pulled back into the cabinet by the drawer's self-closing mechanism

Normal operation

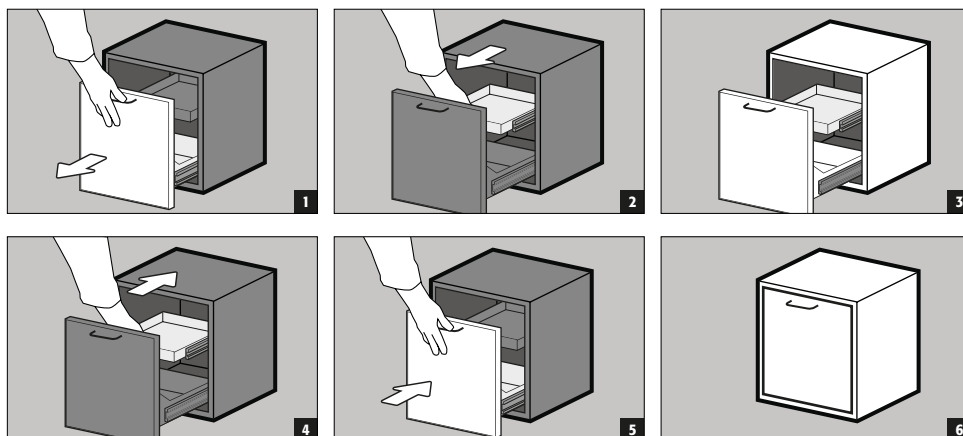

Event of fire

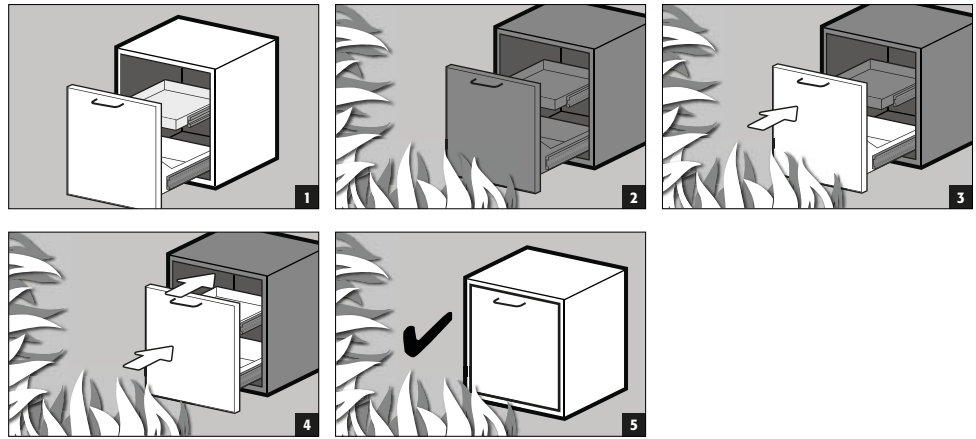

6.3. STORAGE LEVELS WITH POWER SOCKET STRIPS

LOAD CAPACITY (KG/
DRUM PLATFORM)

drawer	Second pull-out level



CAUTION:

Please note that dynamic forces act when loading the cabinets. Always place batteries carefully in the cabinet!



NOTE:

The position of the second level drawer and socket strips cannot be changed.

6.4. TOTAL POWER RATING OF THE POWER SOCKET STRIPS

Standard: single-phase, 230 V

Version	EU	CH	UK	FR	other regions:
fusing	16 A	10 A	13 A	16 A	Please get in touch with your asecos contact person. The maximum power and protection may differ here.
max. total power	3,68 kW	2,3 kW	2,99 kW	3,68 kW	



ATTENTION:

The load on the system is to be distributed as evenly as possible over the power socket strips! The individual power strip must not be loaded with more than the specified power max. (see table)!

The necessary fuse protection is to be provided by the customer!

7. STORAGE

7.1. GENERAL INFORMATION ON BATTERIES



ATTENTION:

Never store obviously damaged lithium-ion batteries inside buildings. Dispose of them without delay in disposal containers that are provided outside the building and approved for transport.



CAUTION

Only batteries with a maximum weight of 15 kg may be stored in the cabinets.

7.2. NOTES ON STORAGE AND CHARGING

Storage

- It is recommended to store new and used lithium-ion batteries separately (each on a different storage level) in the safety storage cabinet.

Occupation of the storage levels

For this basic version, asecos recommends a load of 1 kWh per storage level.

8. VENTILATION

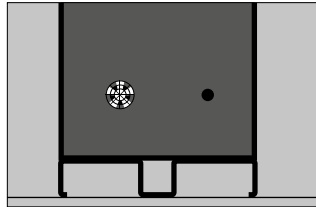

- With model IO90.078.059.057.U9.S, a fan is permanently mounted on the rear of the cabinet.

9. SMOKE DETECTOR



ATTENTION

The entire warning system is only active when connected to the mains power supply. The integrated smoke detector is part of the overall alarm system (direct power supply). In the event of a power failure, the sensors remain active for at least 120 minutes.

10. ERROR - FALSE ALARMS

10.1. ERROR DURING SELF-TEST

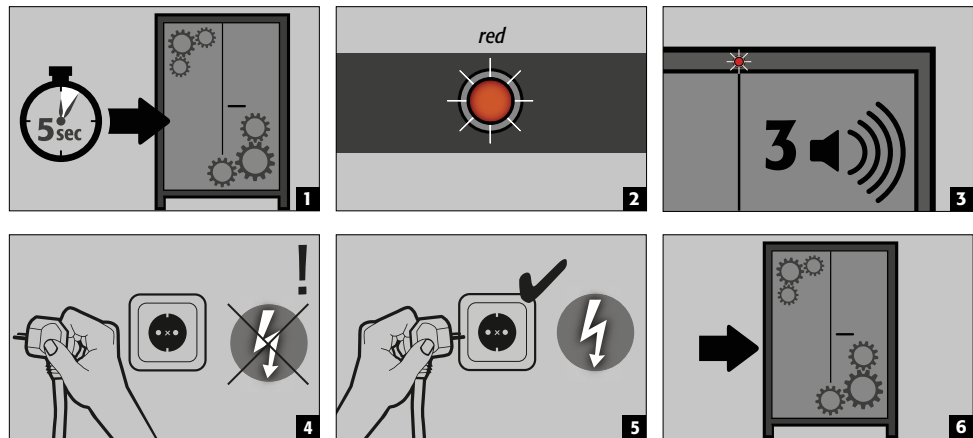

ATTENTION

After disconnecting and reconnecting the power supply, the self-test will start over. If it ends with an error again, please contact the asecos service department.

10.2. FALSE ALARM OF THE SMOKE DETECTOR

- By interrupting the power supply for a few seconds, the smoke detector is reset and the system returns to normal operation.

11. ALARM OVERVIEW

11.1. ERROR AND ALARM OVERVIEW

EVENT	LED	ACOUSTIC ALARM	ACTIONS
Error during self-test	red	3 beeps	1.) Restart by unplugging the device . . If the error persists: 2.) Contact customer service
Power failure	flashing red every 20 seconds	3 short beeps indicating 60 seconds	Check power supply
Smoke alarm	flashing red	rapid tone interval (every 0.25 seconds)	see 11.2
Door cannot close within 60 seconds	flashing green	Sound interval every 1 second	remove blockage

11.2. SMOKE ALARM

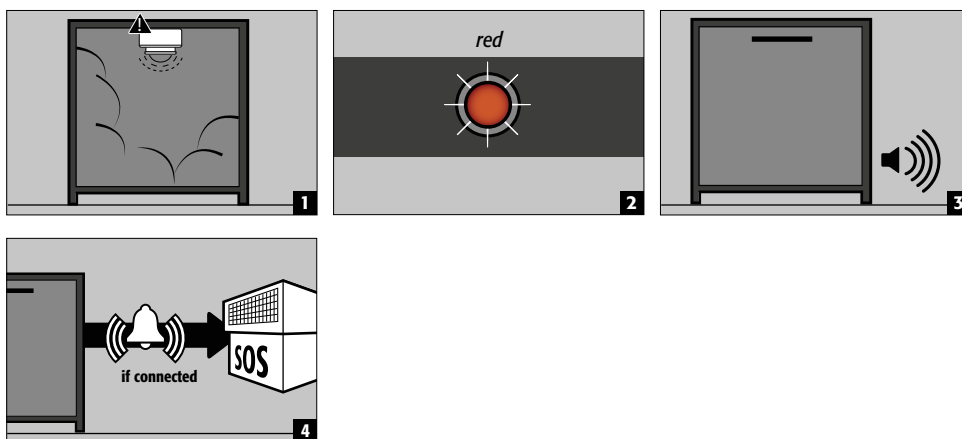

- Actions**
 Immediate visual inspection of the system **by technical personnel (e.g. fire brigade)**.
 Subsequently, initiation of necessary actions.
 If the smoke detector does not detect any further smoke development in the cabinet, the system can be reset to normal operation by briefly disconnecting the mains voltage.

12. BATTERY FIRE - EVENT OF FIRE - DISPOSAL

12.1. OPENING THE CABINET AFTER THE FIRE



CAUTION:
Do not open the cabinet until it has cooled down. This is 6 times the fire duration!
The cabinet may only be opened by authorised personnel (e.g. fire brigade)!
 Depending on the duration of the fire, an ignitable vapour-air mixture may have formed, therefore remove all ignition sources within a 10-metre radius around the cabinets before opening.
 Use only non-sparking tools! Open the cabinets with extreme caution!

12.2. DISPOSAL



The models can be disposed of once they have been dismantled and the materials sorted.

13. SAFETY CHECKS

As safety equipment the cabinets have to be checked for safety at least once per year. The next checking date can be taken from the service sticker on the outside of the door. This annual check can be carried out with the necessary care, and for securing your warranty claims in the case of fire, only by an authorised asecos employee (refer also to our service brochure regarding this).

13.1. CLEANING

The cabinets can be cleaned with a mild household cleaner and a soft cloth. In case of damage please contact your dealer in order to have the cabinet repaired using original spare parts.

13.2. CONTACT



CONTACT:
 In the case of defects or complaints about our products (within and also after the warranty period), and for requesting safety checks or taking out a service contract, please contact our service hotline on:
 Tel: +44 1785 22 70-90 | info@asecos.co.uk (for great Britain and Ireland)
 Tel: +49 1805 92 20 92 | service@asecos.com (international)

14. TECHNICAL DATA

ION-CORE-90		IO90.078.059.057.U9.S	IO90.078.059.057.U1.S
Type		90	90
External dimensions W x D x H	mm	593 x 574 x 780	593 x 574 x 780
Internal dimensions W x D x H	mm	470 x 452 x 582	470 x 452 x 582
Weight without interior equipment	kg	130	130
Distributed load	kg/m ²	461	461
Entry width transport base	mm	545	545
Entry height transport base	mm	90	90
Max. shelf load (evenly distributed)	kg	25	25

Electrotechnical data

Nominal voltage	V	230	230
Frequency	Hz	50/60	50/60
Nominal Power Consumption	W	8	3

Total power rating of the power socket strips

		EU	CH	UK	FR/BE
fuse protection (1-phase)	A	16	10	13	16
max. power (1-phase)	kW	3,68	2,3	2,99	3,68

15. TECHNICAL DRAWING

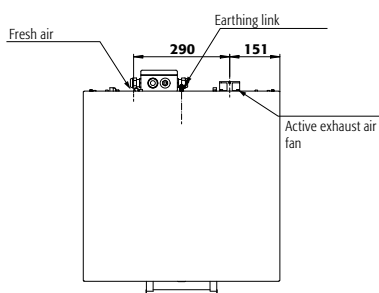

IO90.078.059.057.U9.S

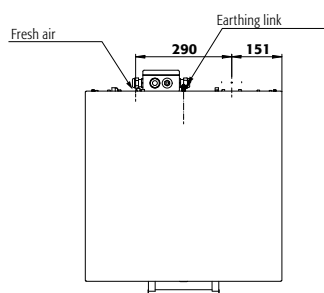

IO90.078.059.057.U1.S

asecos GmbH

Sicherheit und Umweltschutz
Weiherfeldsiedlung 16-18
DE-63584 Gründau

📞 +49 6051 92200
☎ +49 6051 922010
@ info@asecos.com

Asecos BV

Veiligheid en milieubescherming
Christiaan Huygensweg 4
NL-2408 AJ Alphen a/d Rijn

📞 +31 172 506476
☎ +31 172 506541
@ info@asecos.nl

asecos SARL

Sécurité et protection de l'environnement
7 rue du Pré Chaudron
FR-57070 Metz

📞 +33 3 87 78 62 80
@ info@asecos.fr

asecos S.L.

Seguridad y Protección del
Medio Ambiente
C/ Calderí, s/n – Ed. CIM Vallés, Planta 11
08130 – Santa Perpètua de Mogoda
Barcelona

📞 +34 935 745911
☎ +34 935 745912
@ info@asecos.es

asecos Ltd.

Safety and Environmental Protection
Profile House
Stores Road
Derby, Derbyshire
DE21 4BD

📞 +44 1332 415933
@ info@asecos.co.uk

asecos

Safety and Environmental Protection Inc.
c/o Schumann Burghart LLP
1 Penn Plaza, Suite 4440
New York, NY 10119, USA

📞 +1 (917) 362 5014
☎ +49 6051 922010
@ info@asecos.com

asecos Schweiz AG

Sicherheit und Umweltschutz
Gewerbe Brunnmatt 5
CH-6264 Pfaffnau

📞 +41 62 754 04 57
☎ +41 62 754 04 58
@ info@asecos.ch

asecos AB

Säkerhet och miljöskydd
Typsnittsgatan 4
754 54 Uppsala

📞 +46 18 34 95 55
@ info@asecos.se