

EN

EP.V.35857.03 | 05/2026

asecos®



ION
LINE

ULTRA

USER MANUAL

Safety storage cabinets for storage
and charging of lithium ion batteries

ION_{LINE}

ION-ULTRA-90



IO90.195.120.065.WDEL



asecos GmbH
Customer service
Weierfeldsiedlung 16–18
D-63584 Gründau

Fax: +49 60 51 - 92 20-10
email: service asecos.com

YOUR PERSONAL DOCUMENTATION TO THE asecos SAFETY CABINET

Dear Customer,

you have made a decisive investment in safety for your company by purchasing this asecos safety storage cabinet. You now own an innovative product made of top-quality materials guaranteeing the highest quality standards.

asecos safety storage cabinets have complete authorisation documents. We archive the authorisation documents for every individual cabinet, keeping them ready for you should you ever need them (e.g. for a works inspection or similar). Simply request them using this form.

Tear of or copy that page and return to us by fax with your address and serial number of the cabinet on it.

Yours sincerely
asecos GmbH

Contact

Company		
<input type="text"/>		
Street	Postal code	Town
<input type="text"/>	<input type="text"/>	<input type="text"/>
Name of contact person		
<input type="text"/>		
email	Phone No.	
<input type="text"/>	<input type="text"/>	
Serial numbers of safety storage cabinets		
<input type="text"/>	<input type="text"/>	<input type="text"/>
<input type="text"/>	<input type="text"/>	<input type="text"/>
<input type="text"/>	<input type="text"/>	<input type="text"/>
<input type="text"/>	<input type="text"/>	<input type="text"/>

1. NOTES • GUIDELINES • GUARANTEE	5
1.1. General safety notes	5
1.2. Safety instructions for the storage of lithium-ion batteries	5
1.3. Guarantee	5
1.4. Cabinet Details	5
2. TRANSPORT	6
2.1. Tilting the cabinet	6
2.2. Dismantling of the transport packaging	6
2.3. In-plant transport	6
3. INSTALLATION	7
3.1. Alignment Of The Cabinets	7
4. COMMISSIONING	7
4.1. Connection to the power supply	8
4.2. Status LED and reset button	8
4.3. Self-test	8
4.4. Alarm relay	9
5. DOOR OPENING AND CLOSING • LOCKING SYSTEM	9
5.1. In general	9
5.2. Door opening and closing	10
5.3. Door arrest	10
5.4. Automatic door closing with presence sensor (optional)	10
5.5. Automatic door closing system	10
5.6. Blocking the doors during the closing process	10
5.7. Three-point locking system	10
5.8. Lock design	11
5.9. Unlocking when the fusible link is triggered	11
6. INTERIOR FITTINGS	11
6.1. Bottom collecting sump	11
6.2. Insolated Shelves (height-adjustable)	12
6.3. Total power rating of the power socket strips	12
7. STORAGE	13
7.1. General information on batteries	13
7.2. Notes on storage and charging	13
8. VENTILATION	13
8.1. Smoke detector	13
8.2. Pressure relief	13
9. ERROR • FALSE ALARMS	14
9.1. Error during self-test	14
9.2. False alarm of the smoke detector	14
10. FAULT AND ALARM OVERVIEW	14
10.1. Fault messages	14
10.2. Alarm messages	15
10.3. Closing and opening the supply air damper in the event of a fault	15
11. WARNING AND OPTIONAL FIRE SUPPRESSION SYSTEM	15
11.1. Warning message	16
11.2. Alarm level 1 - Smoke alarm	16
11.3. Alarm level 2 - temperature rises above 59°C	16
11.4. Alarm level 3 - smoke and temperature rises above 70°C	17
12. BATTERY FIRE • EVENT OF FIRE • DISPOSAL	17
12.1. Opening the cabinet after the fire	17
12.2. Disposal	18
13. SAFETY CHECKS	18
13.1. Service interval	18
13.2. Cleaning	18
13.3. Contact	18
14. TECHNICAL DATA	18
15. TECHNICAL DRAWING	19

1.1. GENERAL SAFETY NOTES

- Work on the electrical system is to be carried out only with the power turned off and only by qualified electricians – refer here to the regulations of the local electricity supply company.
- General damage to electronic components is to be repaired without delay by an asecos employee.
- Use only intact and undamaged mains cables for the battery charger
- Electrical protection in accordance with local standards must be provided by the customer (cabinets do not have their own RCD circuit breaker or circuit breaker)
- The on-site installation conditions are to be observed.
- The instructions of the supervisory engineering department must be followed.
- Observe accident prevention regulations and workplace ordinance
- **Ensure that the necessary safety checks are only carried out by authorised staff using original spare parts**
- Doors are equipped with automatic self-closing (TSA). This takes place either when the doors leave the swivel range (with optional presence sensor) or time-controlled (standard). The doors must therefore not be closed manually.
- The doors must be locked when not in use. See point "Locking"
- Only use the cabinet after having been properly instructed; access is to be forbidden to unauthorised persons.
- The pivoting area of the doors is to be kept free at all times; doors are to be kept closed
- By assigning trained/authorised technical personnel you can prevent the malfunctions, damage and corrosion damage that result from inappropriate transport.
- Observe the upper limits for stored quantities, loading etc.
- ION-LINE safety storage cabinets are designed exclusively to store and charge lithium-ion batteries. Storing them together with other (hazardous) substances is not permitted.
- **Observe the notes on maximum size and general storage of the batteries in these instructions**

Set-up requirements

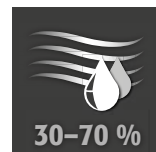
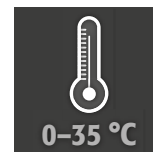

CAUTION

Do not install the cabinet near fire hazards!

1.2. SAFETY INSTRUCTIONS FOR THE STORAGE OF LITHIUM-ION BATTERIES

- Any charger included will switch off in the event of fire or overheating
- When handling lithium-ion batteries, observe the applicable regulations and the information in these operating instructions
- Follow the instructions for storing your batteries in accordance with the battery manufacturer's operating instructions
- Batteries can produce toxic gases, therefore connection to an exhaust air system is recommended.
- Alternatively, a risk analysis must be carried out. The result determines whether additional safety measures are necessary to minimize the risk of toxic, flammable gases in the work area.

1.3. GUARANTEE

The guarantee for this product is agreed between you (the customer) and your dealer (the seller). As the manufacturer, asecos guarantees the products listed in the operating instructions for a period of 24 months from the date of delivery. All model safety equipment are subject to a compulsory annual inspection by specialised staff authorised by the manufacturer. Otherwise the customer's guarantee claim against the manufacturer expires. Please note that the warranty is also void if holes are drilled or modifications are made without consulting the manufacturer asecos.

1.4. CABINET DETAILS

Cabinet data: logbook (included with the cabinet)

Technical drawing: see appendix

Technical data: table in appendix

ION-ULTRA-90

Safety storage cabinets for lithium-ion batteries

Extended protection for professional handling of lithium-ion batteries including 3-stage alarm and optional active fire suppression system. During active storage, lithium-ion batteries or battery packs are charged or partially discharged (60-70%) in the cabinet using a charger.

2. TRANSPORT

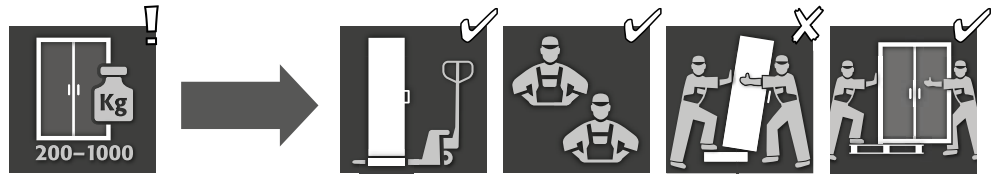

CAUTION:

Transport the cabinet in an upright position on a pallet truck, tied and secured against slipping, until the final place of installation is reached. The transport locks in the door joints may only be removed directly at the place of installation! Inappropriate transport can lead to concealed damage to the fire protection insulation! We can only guarantee the necessary quality if the cabinet is transported to the place of its use by our specially trained staff.



CAUTION:

The doors must be closed before transport!

2.1. TILTING THE CABINET

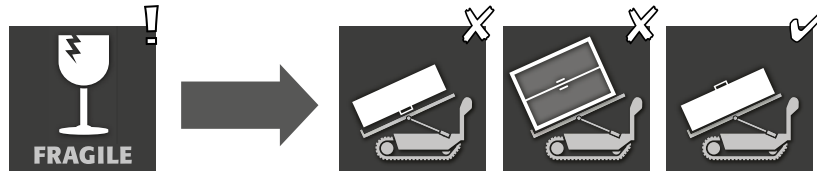

CAUTION:

Tilting the cabinet may only be done without jolts! When using a stair robot, observe the maximum load capacity of the device according to the manufacturer's instructions!

2.2. DISMANTLING OF THE TRANSPORT PACKAGING

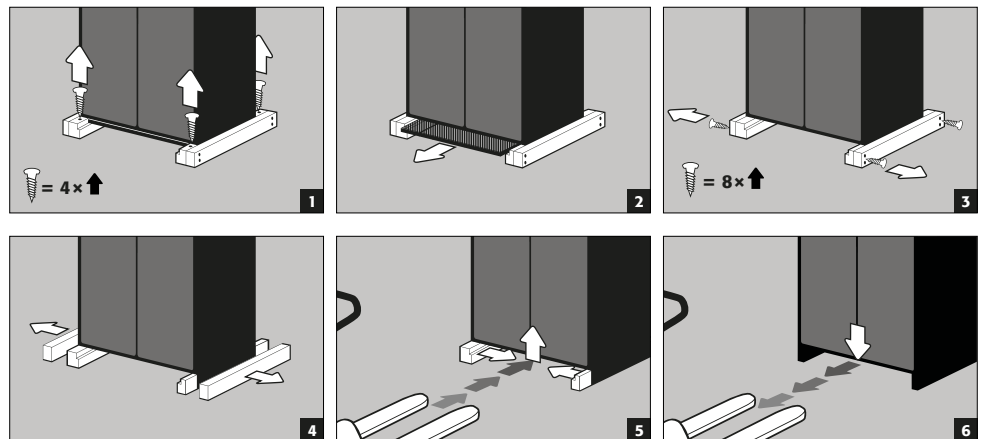

2.3. IN-PLANT TRANSPORT

- Can also be used without transport locks (inserted in the door joints as standard)
- The cabinets are equipped with a transport base for internal transportation or for tactical measures following a battery fire.
- The cabinets are automatically disconnected from the power supply during transportation.
- After a battery fire, this must only be carried out by qualified personnel (e.g. fire department) wearing personal protective equipment.
- Transportation by at least 2 persons is recommended!



CAUTION:
The doors must be locked before transport! Depending on the door heights, it may be necessary to remove the ventilation attachment beforehand. Transport may only be carried out by qualified personnel!

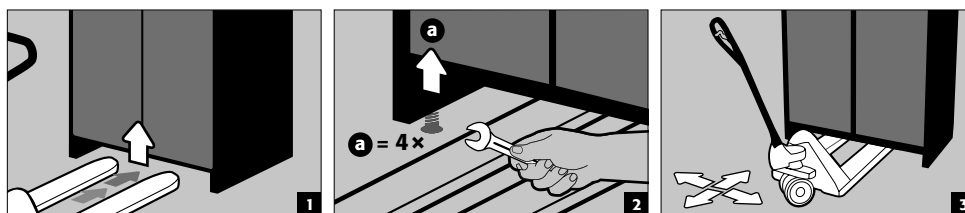

3. INSTALLATION

3.1. ALIGNMENT OF THE CABINETS

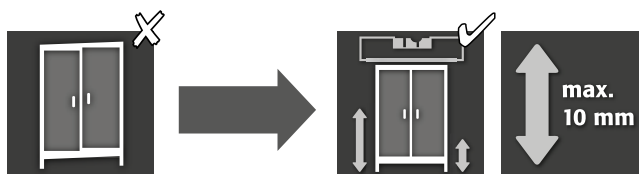

CAUTION:
Door elements must not scrape against the fire prevention seals in the fold of the door when opening and closing! Doors with an automatic closing mechanism must close automatically from every position and the lock must be able to lock!

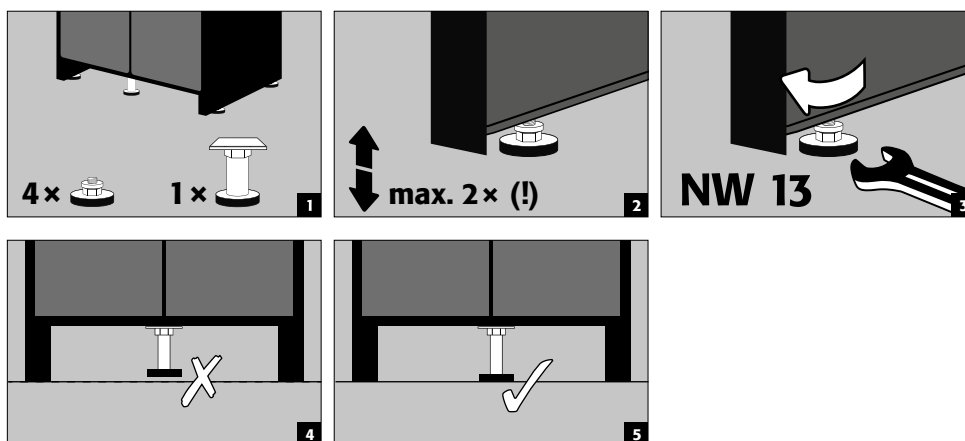

4. COMMISSIONING

- Before putting into operation for the first time, the user must carry out an examination of the safety storage cabinet for possible damage, such as defective or loose sealing elements, correct alignment and perfect functioning of the door elements.
Use the cabinet and accessories only if they are in an orderly condition.

4.1. CONNECTION TO THE POWER SUPPLY

Connections on the headpiece:

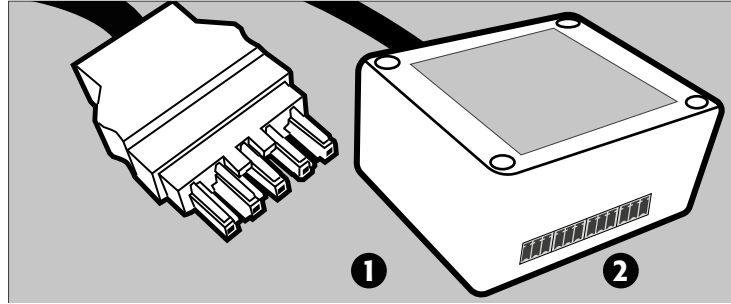

1 Mains plug connector

2 Alarm relay

Connection to the power supply

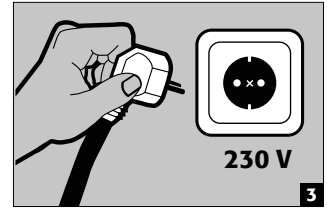
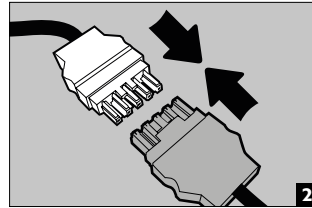
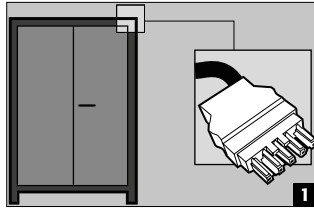

Connection to the power supply with 400 V (optional with item 38038)

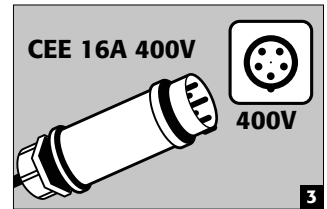
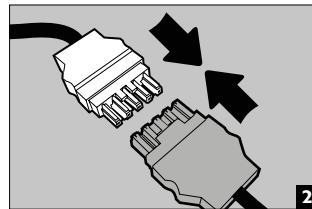
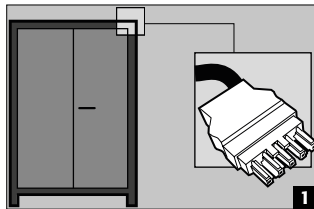

NOTE:

Retrofitting is easy due to the plug-in connection, so that no intervention in the electrical components is necessary. The power supply must be fused on site with a maximum of 16A. Electrical protection in accordance with local standards must be provided on site. The cabinets do not have their own RCD circuit breaker or circuit breaker.

4.2. STATUS LED AND RESET BUTTON

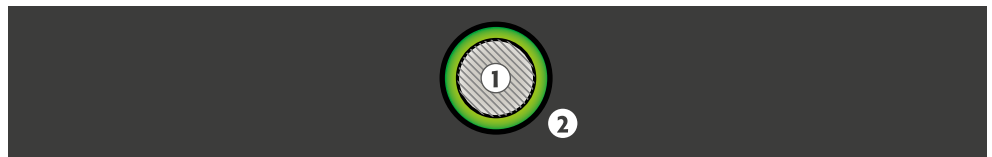

1 RESET BUTTON 2 LED: Operating (green) / Error (red)

4.3. SELF-TEST

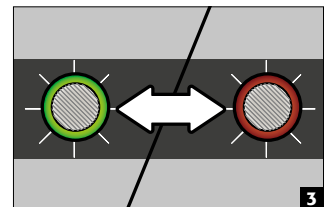
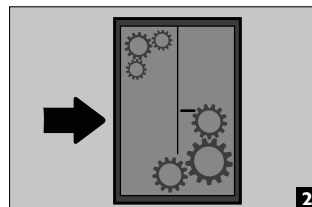
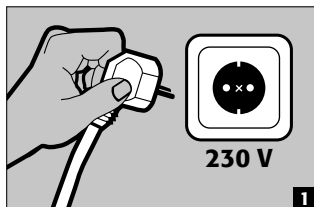

4.4. ALARM RELAY

- The alarm relays of the main electronics are routed to the outside via a connection box equipped with plug-in connectors.
- The housing is attached to the top of the cabinet using Velcro

The alarm relays switch the states, each using a monostable changeover relay, as follows:

- Relay K1: Warning message/Alarm Level 2
- Relay K2: Alarm Level 1
- Relay K3: Alarm Level 3
- Relay K4: System error/power failure

Each relay has a:

- Normally closed (NC)
- Normally open (NO)
- Changeover contact (CO)
- The relays for the warning message / Alarm Level 2 (K1), Alarm Level 1 (K2), and Alarm Level 3 (K3) are energized (High-Level) in the respective alarm event.
- The relay for power failure (K4) is energized (high level) as soon as mains voltage is applied to the cabinet and de-energizes (low level) in the event of a power failure.
- The relay contacts are each rated for a maximum DC voltage of 30 V or an AC voltage of 30 V.
- The maximum current rating is 2 A.
- The maximum switching capacity of each relay is 60 W.



NOTE:
The switching contacts are used to connect a signal to a control centre/control room. Direct integration into a fire alarm control centre is not recommended or may only be carried out in consultation with the person responsible for the system. The switching contact used is connected on site using the enclosed plug connections (see illustration). The housing must remain attached to the cabinet. This ensures automatic disconnection in the event of removal.

Performance data	
Max. Switching voltage DC	30 V
Max. Switching voltage AC	30 V
Max. switching current	2 A
Max. Switching capacity	60 W/VA

5. DOOR OPENING AND CLOSING - LOCKING SYSTEM

5.1. IN GENERAL

- The lockers can be opened by operating the door handle (see 5.2)
- They are also equipped with an automatic door closing system. This is controlled either by a presence sensor (see 5.4) or by a timer (see 5.5)
- The doors are locked as soon as they have closed automatically
- The tinted doors are permanently self-closing, unless they have been locked by means of a door lock (see 5.3)



ATTENTION:
The owner/user must ensure that all doors are kept closed whenever the contents of the cabinet are not being accessed. In general, it must be noted that the cabinets do not possess an emergency unlocking facility. This means that persons trapped inside the cabinet cannot free themselves!

5.2. DOOR OPENING AND CLOSING

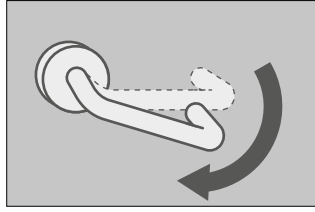

- To open the doors, the door handle must be pressed down and the door pulled open
- Both doors are always opened simultaneously
- The doors can be locked by means of a door stop
- Otherwise, they are permanently self-closing and fall into the lock automatically when released

5.3. DOOR ARREST

- For convenient handling, the doors can be locked with the door locking system
- To do this, the doors are opened until they engage audibly



CAUTION

Do not push the doors closed by hand, as this can damage the mechanics! The doors close automatically using the automatic door closing system!

5.4. AUTOMATIC DOOR CLOSING WITH PRESENCE SENSOR (OPTIONAL)

- When using the presence sensor, the doors remain open while the locker is in active use.
- If the user leaves the immediate vicinity of the open cabinet, the doors close automatically



CAUTION:

Only the area up to approx. 100 cm above the floor can be detected.

5.5. AUTOMATIC DOOR CLOSING SYSTEM



ATTENTION:

The doors close automatically. Do not push the doors shut by hand, as this can damage the mechanism! Premature closing can be triggered by pressing the reset button.

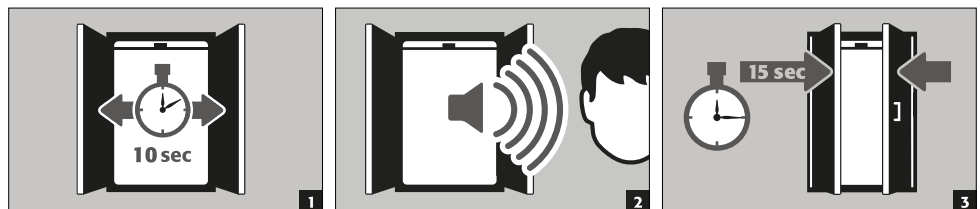

5.6. BLOCKING THE DOORS DURING THE CLOSING PROCESS



CAUTION:

If the doors are blocked during the closing process and cannot close completely, the cabinet signals a fault after 15 seconds. The LED flashes green and an intermittent tone sounds. If you remove the blockage, the doors close automatically and the fault signal goes out.

5.7. THREE-POINT LOCKING SYSTEM

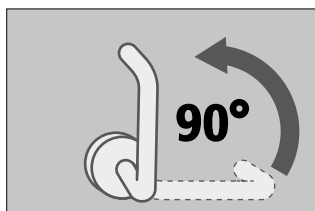

- Closed doors must always be locked using the 3-point locking system!
- To do this, the door handle must be turned 90° upward



CAUTION:
If the door handle is in the 3-point locking position when the doors are open, the doors can no longer close completely on their own.

5.8. LOCK DESIGN



- The lockers have a profile cylinder lock with locking status indicator.
- They can be integrated into a locking system.
- A profile half cylinder (30/10) with adjustable locking lug must be used.

5.9. UNLOCKING WHEN THE FUSIBLE LINK IS TRIGGERED

- If the fuse in the front head section has blown, the door is locked.
- Place the supplied emergency release hook in the designated position in the front headrest area.
- Press down on the rear leg with the hook. This will lift the drop bolt against the existing spring tension.
- Once the drop bolt is raised, the door can be opened manually.

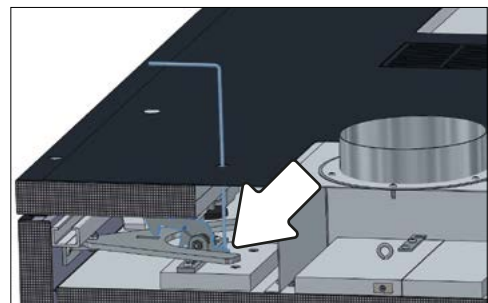
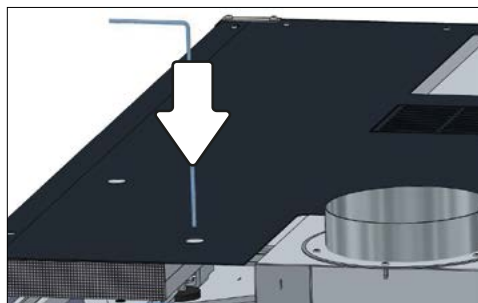

6. INTERIOR FITTINGS

6.1. BOTTOM COLLECTING SUMP



As liquid (e.g. electrolyte liquid) can escape from a lithium-ion battery during a fire, the safety storage cabinet has a base tray in accordance with DIN EN 14470 Part 1 with a capacity of at least 1 litre.

Leaks:

- Liquid in the sump is to be collected using suitable means.
- The choice of means is your own responsibility.

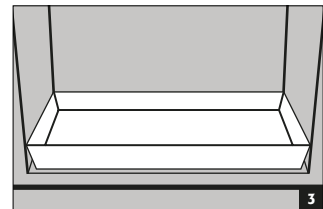
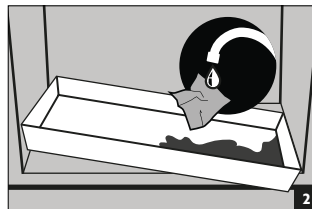
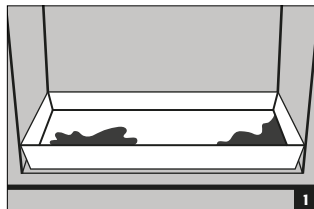

6.2. INSOLATED SHELVES (HEIGHT-ADJUSTABLE)

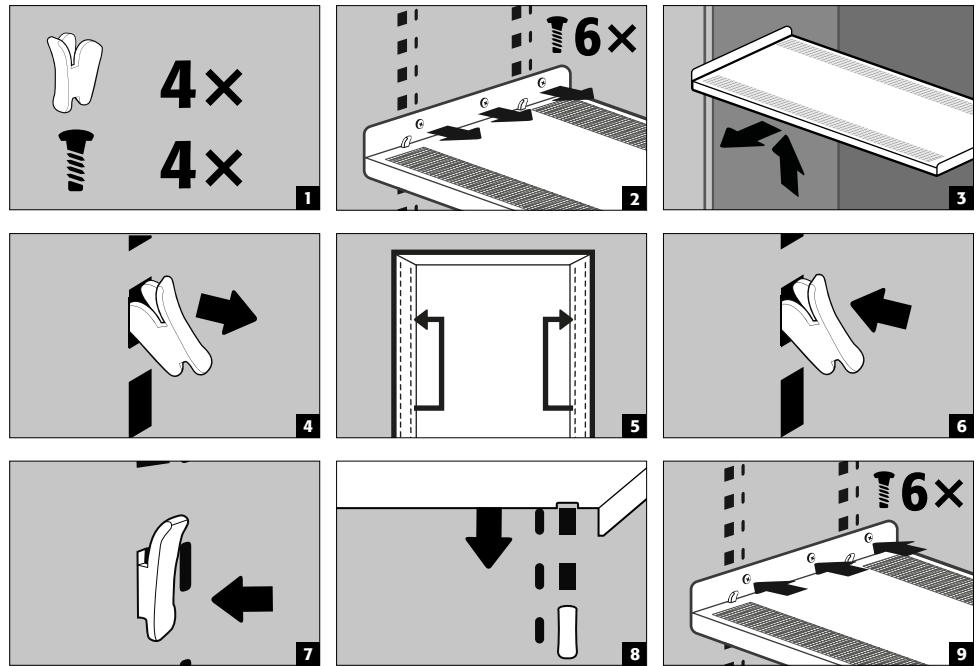

Load capacity (kg/drum platform)



CAUTION:

Please note that dynamic forces act when loading the cabinets. Always place batteries carefully in the cabinet!



CAUTION:

The position of the socket strips cannot be changed.

6.3. TOTAL POWER RATING OF THE POWER SOCKET STRIPS

Standard: single-phase, 230 V

Version	EU	CH	UK	FR	other regions:
fusing	16 A	10 A	13 A	16 A	Please get in touch with your asecos contact person. The maximum power and protection may differ here.
max. total power	3,68 kW	2,3 kW	2,99 kW	3,68 kW	

Optional: 3-phase, 400 V (accessories article 38038)

Version	EU	CH	UK	FR	other regions:
fusing	3 x 16 A	3 x 10 A	3 x 13 A	3 x 16 A	Please get in touch with your asecos contact person. The maximum power and protection may differ here.
max. total power	11,04 kW	6,9 kW	8,97 kW	11,04 kW	



ATTENTION:

The load on the system is to be distributed as evenly as possible over the power socket strips! The individual power strip must not be loaded with more than the specified power max. (see table)!

The necessary fuse protection is to be provided by the customer!

7. STORAGE

EN

7.1. GENERAL INFORMATION ON BATTERIES



ATTENTION:

Never store obviously damaged lithium-ion batteries inside buildings. Dispose of them without delay in disposal containers that are provided outside the building and approved for transport.



CAUTION

Only batteries with a maximum weight of 15 kg may be stored in the cabinets.

7.2. NOTES ON STORAGE AND CHARGING

Storage

- It is recommended to store new and used lithium-ion batteries separately (each on a different storage level) in the safety storage cabinet.

Occupation of the storage levels

- The batteries inside the cabinet should be distributed as evenly as possible and inserted at a suitable distance from each other. Further information > see Chapter 14. Technical data



CAUTION:

The following substances must not be stored in cabinets with a fire suppression system:
Acids, bases, magnesium, other metals (in powder form).

Heat is generated during the charging of a lithium-ion battery!

Please note: The technical ventilation (to prevent heat build-up in the interior) must be kept permanently in operation.

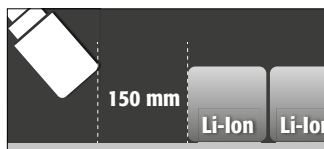

CAUTION:

A distance of min. 150 mm must be maintained in the area in front of the fire suppression unit.

8. VENTILATION

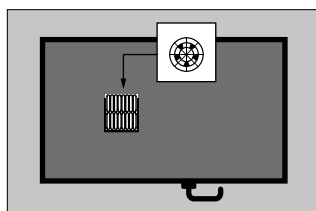

- This model features a fan permanently installed in the top section of the cabinet.
- The ventilation speed is automatically regulated by the unit and depends on the temperature inside the cabinet
- The built-in fan provides a maximum air change rate of 30 m³/h.

8.1. SMOKE DETECTOR



ATTENTION:

The complete warning/fire suppression system is active only with mains operation. The integrated smoke detector is part of the entire fire suppression system (direct power supply).

8.2. PRESSURE RELIEF

All ION-LINE models are equipped with a pressure relief valve built into the head section. In the event of a brief, extreme increase in pressure inside the cabinet, this valve opens briefly to ensure that the safety storage cabinet remains sealed (the doors remain closed).

Flue Gas Management

A DN 160 adapter is included to ensure that toxic flue gases are directed through a customer-provided exhaust duct to a safe location outdoors. To make the connector, remove the hole insert and attach the included connector using the provided sheet metal screws. The exhaust system must not allow any gases to enter work areas.

**NOTE**

The connector **must not** be connected to an existing exhaust air system. A separate flue gas outlet is required. The customer's exhaust air system should be designed to allow for a minimum volumetric flow of 30 m³ per hour.

9. ERROR - FALSE ALARMS

9.1. ERROR DURING SELF-TEST

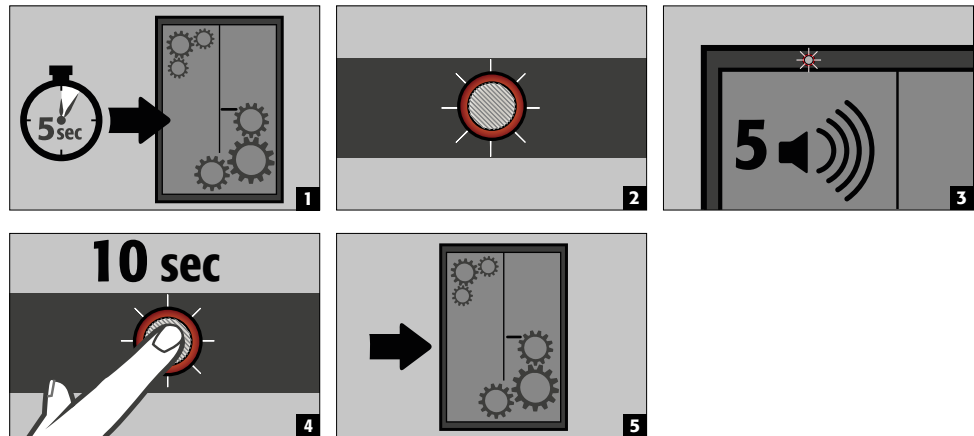
**ATTENTION:**

After pressing the reset button, the self-test begins again. If the error persists, please contact the asecos Service department.

9.2. FALSE ALARM OF THE SMOKE DETECTOR

- By interrupting the power supply for a few seconds, the smoke detector is reset and the system returns to normal operation.

10. FAULT AND ALARM OVERVIEW

10.1. FAULT MESSAGES

EVENT	LED	ACOUSTIC ALARM	ACTIONS
Error during self-test	red / green flashes alternately	5 signal tones	1.) Restart with RESET button if error persists: 2.) Contact Service
Service interval reached	flashes green	off	Contact Service
Power failure	flashes red every 20 seconds	3 short signal tones every 60 seconds	Check power supply
blockage of the open door, door cannot close completely	flashes red	intermittent tone	remove blockage
sensor error during operation	flashes orange / red	5 signal tones	1.) Check air flaps and open if necessary If error remains: 2.) Contact service

10.2. ALARM MESSAGES

EVENT	LED	ACOUSTIC ALARM	ACTIONS
Warning message: Temperature in the cabinet >50 °C	flashes orange	Interval tone (for approx. 30 seconds)	see 11.1
Alarm level 1: Smoke detector detects smoke in the cabinet	flashes red	fast tone interval (every 0.25 seconds for 125 ms)	Immediate inspection of the system by specialised personnel (e.g. fire brigade). see 11.2-11.4
Alarm level 2: Temperature in the cabinet >59 °C	flashes quickly orange	fast tone interval (every 0.25 seconds for 125 ms)	Immediate inspection of the system by specialised personnel (e.g. fire brigade). see 11.2-11.4
Alarm level 3: Smoke detector detects smoke in the cabinet, Temperature in the cabinet >70 °C	flashes quickly red	fast tone interval (every 0.25 seconds for 125 ms)	Immediate inspection of the system by specialised personnel (e.g. fire brigade). see 11.2-11.4

10.3. CLOSING AND OPENING THE SUPPLY AIR DAMPER IN THE EVENT OF A FAULT



CAUTION:
If a temperature and/or smoke detection of over 60 °C is detected inside the cabinet, the supply air flap in the head section is automatically closed. Once the fault has been rectified, the supply air flap must be opened again manually. Please use the existing inspection flap on the head section for this purpose.

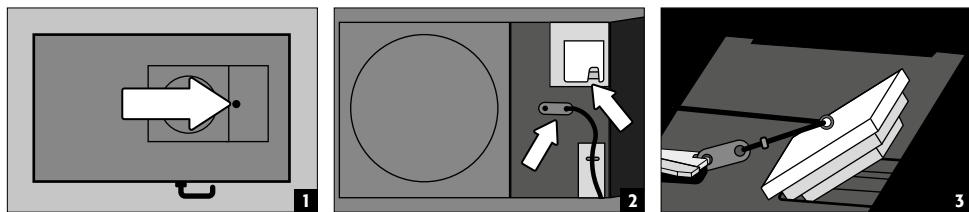

11. WARNING AND OPTIONAL FIRE SUPPRESSION SYSTEM

- The warning/ (optional) fire suppression system offers the option of connection to a constantly manned building management system or fire alarm centre.
- Make use of this option so that trained rescue personnel can be quickly alerted and be on-site in a very short time and, following an initial assessment of the situation, immediately initiate further measures (for example, transporting the cabinet out of the building).
- In this way consequential damage to the building and personal injuries can be avoided.

Cabinets equipped with fire suppression unit

- The extinguishing agent, based on potassium carbonate, is harmless in the necessary extinguishing agent concentration and has no harmful effects on the human organism.
- In case of triggering, the aerosol is ejected at a high temperature and temperatures of over 300 °C are briefly generated in front of and on the housing of the fire suppression cartridge (according to the manufacturer's data, a minimum distance to combustible materials need not be maintained; however, a distance of at least 150 mm to the fire suppression cartridge should generally be maintained).
- After triggering of the fire suppression cartridge, ventilate the room and the cabinet well, observing the instructions in **point 12**.



CAUTION:
The cabinet electronics are equipped with battery buffering. In the event of a power failure, the smoke and temperature sensors remain fully functional for at least 480 minutes (8 hours). If the system has an optional integrated fire suppression system, this will continue to be activated in battery mode if smoke is detected and a temperature of over 70 °C is detected at the same time.

11.1. WARNING MESSAGE

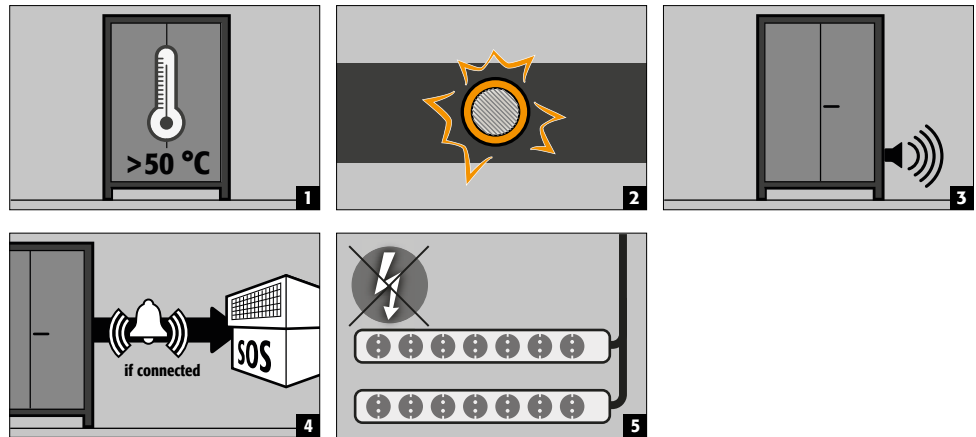

- **Actions**

Immediate visual inspection of the system by the company's own qualified personnel.

Initiation of necessary actions.

If the interior temperature falls below 45 °C, the system returns to normal operation and the visual and acoustic signals are switched off, the sockets are powered again

11.2. ALARM LEVEL 1 - SMOKE ALARM

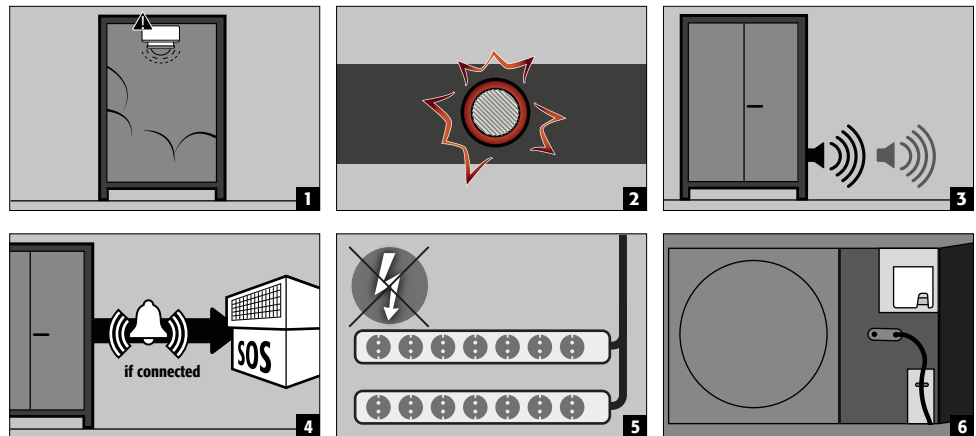

- **Actions**

Immediate visual inspection of the system **by technical personnel (e.g. fire brigade)**.

Subsequently, initiation of necessary actions.

If the smoke detector does not detect any further smoke development in the cabinet, the system can be reset to normal operation by briefly disconnecting the mains voltage.

11.3. ALARM LEVEL 2 - TEMPERATURE RISES ABOVE 59°C

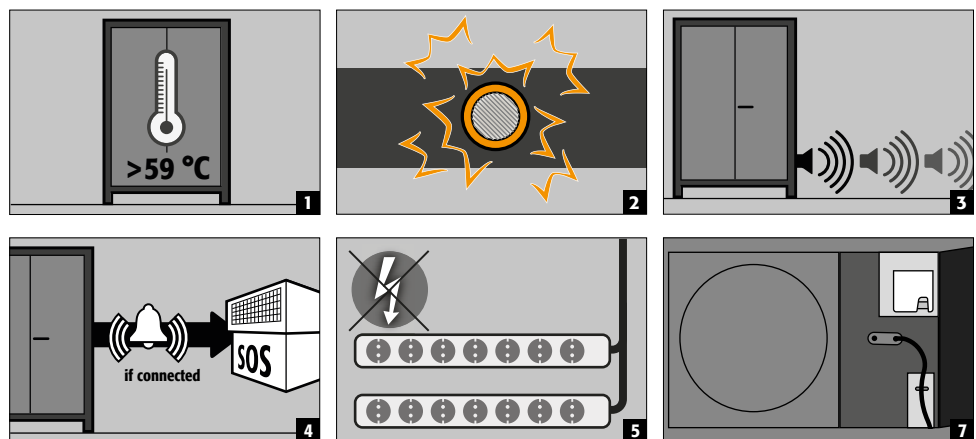

- **Actions**

- Immediate visual inspection of the system **by technical personnel (e.g. fire brigade)**.

- Subsequently, initiation of necessary actions.

- The supply air flap must be hooked in (see 9.3). Then put the system into operation with the reset button.

11.4. ALARM LEVEL 3 - SMOKE AND TEMPERATURE RISES ABOVE 70°C

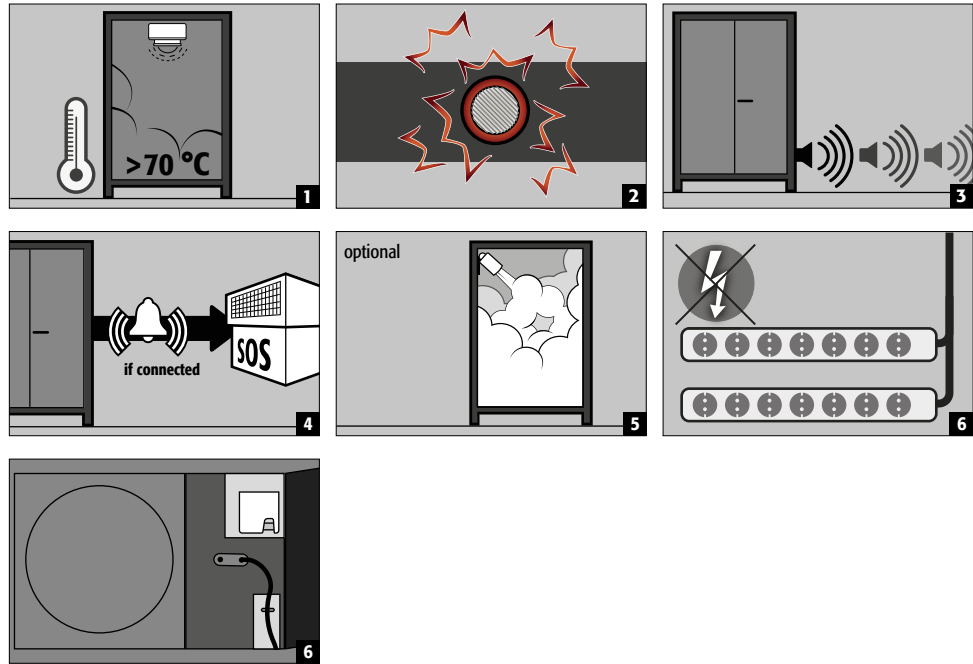

- Actions**
 Immediate visual inspection of the system by **technical personnel (e.g. fire brigade)**.
 Subsequently, initiation of necessary actions.
See 2.3 for the transport of the cabinets out of the building.



PLEASE NOTE:
 After alarm level 2 is triggered, the electronics are disabled for safety reasons. Independent recommissioning by the user is not possible in this state. Unlocking may only be carried out by asecos Service.

12. BATTERY FIRE - EVENT OF FIRE - DISPOSAL



NOTE:
 After the fire suppression device has been triggered, the safety cabinet must be subjected to a thorough inspection so that both fire protection and CE conformity are maintained. For this purpose, the cabinet must be handed over to the main factory of asecos GmbH in Gründau, where the specialist department - depending on the degree of damage - will make an assessment of the economic efficiency and technical possibilities of a repair. The customer then receives an offer of either a repair or a replacement, which can be handed over to the responsible property insurer.

12.1. OPENING THE CABINET AFTER THE FIRE



CAUTION:
Do not open the cabinet until it has cooled down. This is 6 times the fire duration!
The cabinet may only be opened by authorised personnel (e.g. fire brigade)!
 Depending on the duration of the fire, an ignitable vapour-air mixture may have formed, therefore remove all ignition sources within a 10-metre radius around the cabinets before opening.
 Use only non-sparking tools! Open the cabinets with extreme caution!

12.2. DISPOSAL



The models can be disposed of once they have been dismantled and the materials sorted.

13. SAFETY CHECKS

As safety equipment the cabinets have to be checked for safety at least once per year. The next checking date can be taken from the service sticker on the outside of the door. This annual check can be carried out with the necessary care, and for securing your warranty claims in the case of fire, only by an authorised asecos employee (refer also to our service brochure regarding this).

13.1. SERVICE INTERVAL

A necessary service is automatically indicated by the cabinet by a flashing green LED. Within the context of the annual check, the fire suppression system, smoke detector and sensors will be checked in addition to the check of all safety-related parts.



ATTENTION

In accordance with DIN 14676 the proper function of the smoke detector must be checked at least once per year. In addition, we recommend the regular visual inspection of the battery chargers, batteries and connecting cables.

13.2. CLEANING

The cabinets can be cleaned with a mild household cleaner and a soft cloth. In case of damage please contact your dealer in order to have the cabinet repaired using original spare parts.

13.3. CONTACT



CONTACT:

In the case of defects or complaints about our products (within and also after the warranty period), and for requesting safety checks or taking out a service contract, please contact our service hotline on:

Tel: +44 1785 22 70-90 | info@asecos.co.uk (for great Britain and Ireland)

Tel: +49 1805 92 20 92 | service@asecos.com (international)

14. TECHNICAL DATA

ION-ULTRA-90		IO90.195.120.065.WDEL
Type		90
External dimensions W x D x H	mm	1193 x 650 x 1953
Internal dimensions W x D x H	mm	1050 x 545 x 1633
Extraction air connection	DN	160
Weight without interior equipment	kg	585
Distributed load	kg/m ²	602
Entry width transport base	mm	1120
Entry height transport base	mm	90
Volumetric flow rate (recommended)	m ³ /h	30

Power consumption of control electronics

Nominal Power Consumption	W	30
Nominal voltage	V	230/400
Frequency	Hz	50/60

Total power rating of the power socket strips

		EU	CH	UK	FR/BE
Fuse (1-phase)	A	16	10	13	16
Power max. (1-phase)	kW	3,68	2,3	2,99	3,68
Fuse (3-phase)	A	3 x 16	3 x 10	3 x 13	3 x 16
Power max. (3-phase)	kW	11,04	6,9	8,97	11,04

Battery energy according to VDMA standard sheet 24994

Number of storage levels	kWh/storage level	kWh/cabinet
3	3.3	9.9
4	3.3	13.2
5	3.3	16.5
6	3.3	16.5

15. TECHNICAL DRAWING

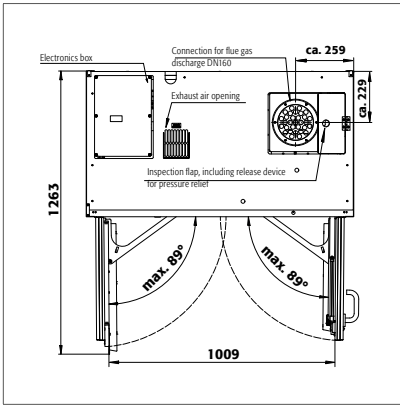

IO90.195.120.065.WDEL

0.4

0.25

0.25

0.25

0.25

0.4

0.4

0.25